



SoftenUp, Plateau Ceiling Frames

Essentials Collection

Options for a more comfortable space are looking up. Designed for effortless installation, Plateau readily fits into 15/16" drop-ceiling T-grid systems. Linear slats absorb unwanted sound while adding visual interest without clutter. Choose from a variety of sizes, slat widths, and colors to personalize your space.

Specifications

Surface	Ceiling	
Material	WhisperTex™ polyester felt	
Thickness	3/8", 9mm (±10%)	
Weight	0.34 lb./ft ² (±10%)	
Standard Sizes	Slat Profiles	Backer Panels
	2" W x 1" H	24" W x 24" L
	4" W x 1" H	24" W x 48" L
		24" W x 96" L
	<i>Custom sizes available</i>	
Compatible T-grid	Type	Layout
	15/16" Flat	Standard 24" x 24"

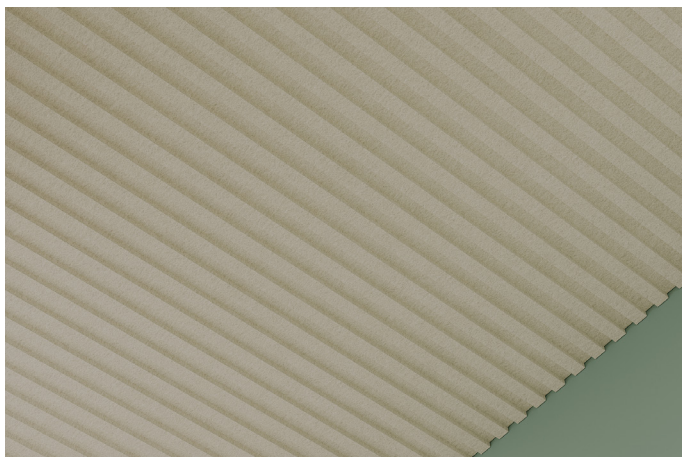

SoftenUp, Plateau 2" W x 1" H Ceiling Frames in Talc

Technical

NRC Rating	Material: 0.35 Product: Testing is pending
Fire Test	ASTM E84, Class 1 Flame spread index: 7 Smoke developed index: 160
Colorfastness	ISO 105-B02, 4

Details

Lead Time	3 – 6 weeks
Origin	Manufactured and assembled in the US
Warranty	Product: 12 years* Colorfastness: 12 years*

* Conditions apply

Environmental

Recycled Content	Minimum 55%
Indoor Air Quality	VOC less than/equal to 0.5mg/m ³
Recyclable	100%*
Certifications	TVOC emissions rate

* PET is recyclable through participating partners.



Colorways

ESSENTIALS

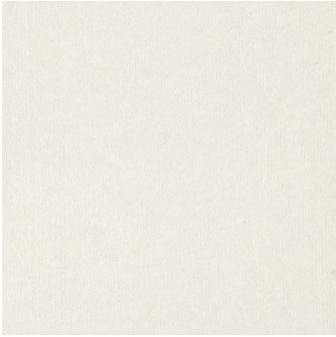

Talc
TA08

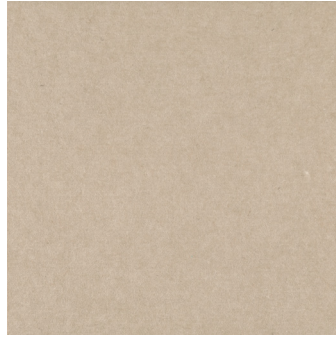

Limestone
LI07

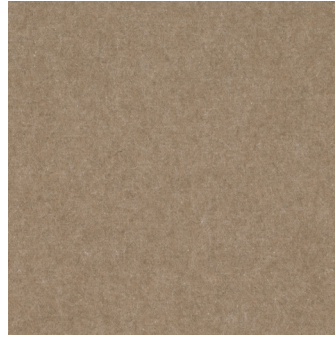

Silt
SI06

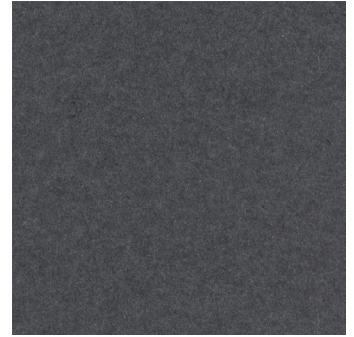

Shale
SH03



Pumice
PU05



Gypsum
GY04

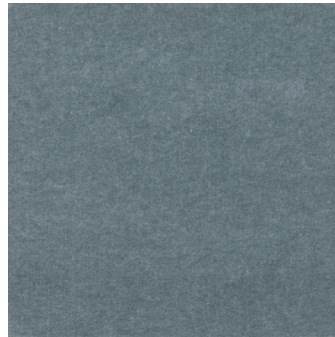

Jade
JA02



Basalt
BA01

Order samples at acoufelt.com/colorways

How to Specify

1. Choose Slat Size

2. Choose Backer Panel Size

3. Choose Colorways

Slats are available in two sizes:

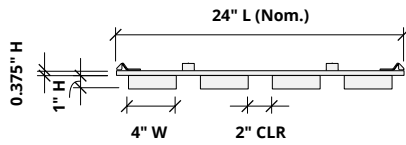
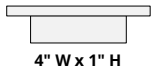
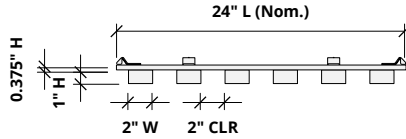

1. Choose Slat Size

2. Choose Backer Panel Size

3. Choose Colorways

Backer panels are available in three sizes for use with 2" and 4" slats.

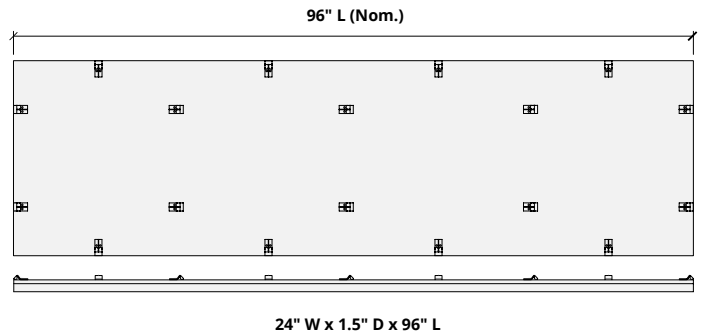
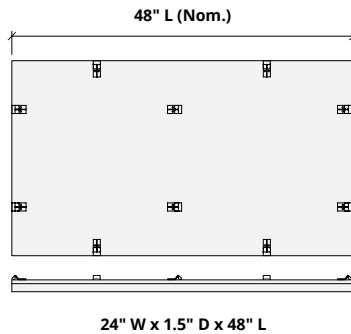
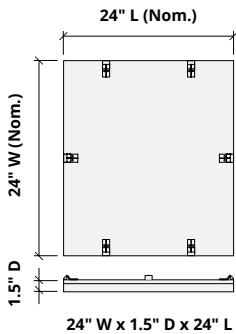

Drawings show spacing for 2" W slats. Spacing for 4" W slats will differ. Product ships assembled.

1. Choose Slat Size

2. Choose Backer Panel Size

3. Choose Colorways

Select one colorway for your slats and one colorway for your backer panel. See colorway choices on page 3.

If you're specifying dark colored backer panels, we recommend dark drop ceiling grids (not provided).

Backer panel
Select one colorway

Slats
Select one colorway

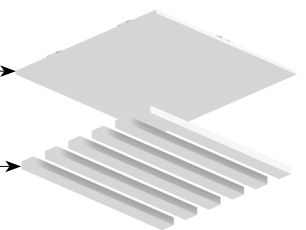

Recommended Layouts

Layout 1

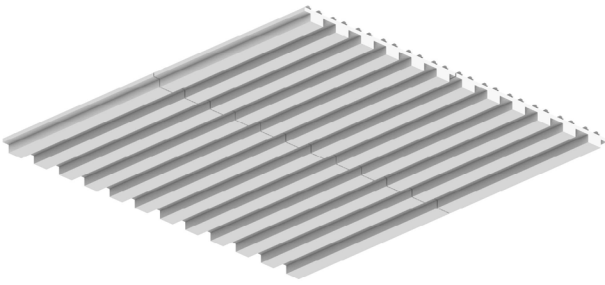

Layout 2

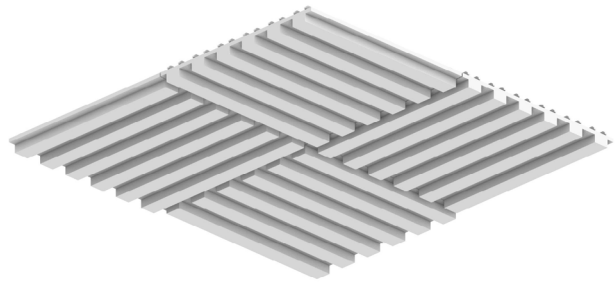

Layout 3

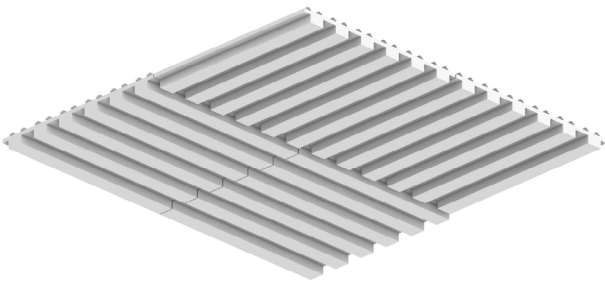

Layout 4

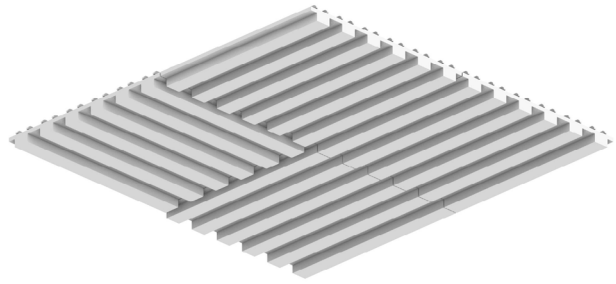

Lighting Coordination

24" x 24", 24" x 48" Grid light

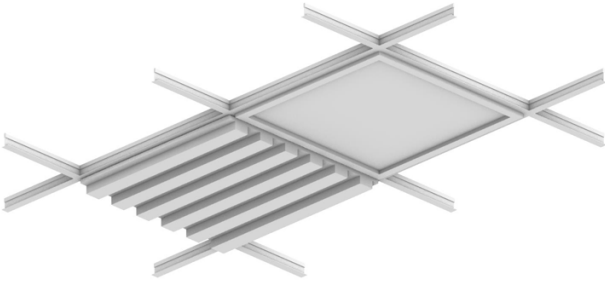

Drop pendant light

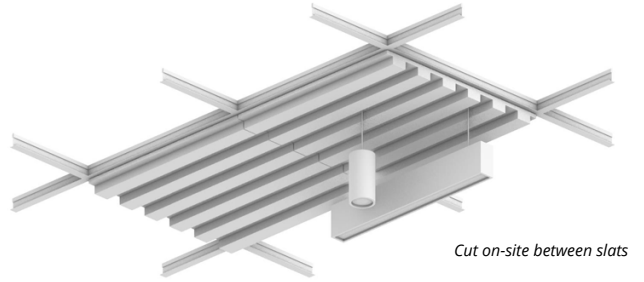

Recessed light

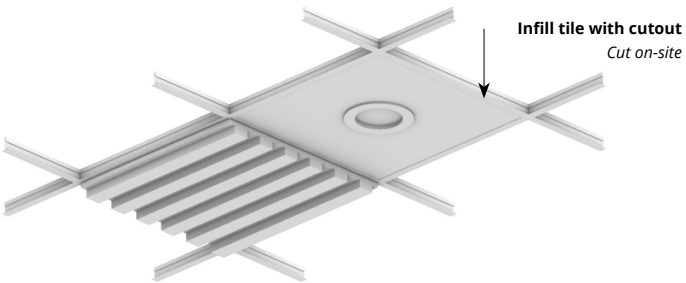

Grid mounted light (track, pendant)

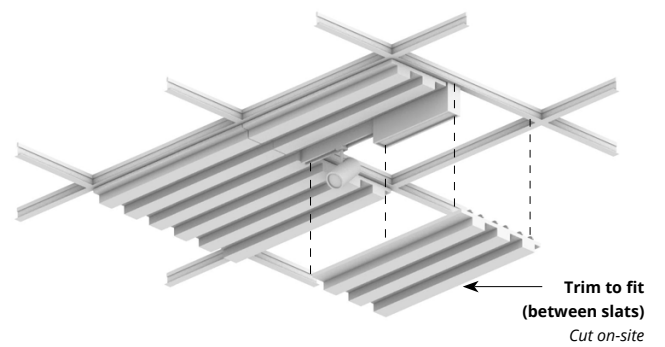

Suspension

The SoftenUp ceiling tiles are designed to connect to standard drop-ceiling grid systems via a series of tabs integrated into the design. No additional hardware is required for standard installation. Seismic zones may require additional considerations (see note on seismic).

Life Safety

The panels can be trimmed on-site, using a sharp utility knife, to accommodate any existing signage and/or wayfinding markings. Cut-outs must occur in 2" gap between slats. All fixtures must be supported independent of tiles.

** Panels cut on-site may require additional support.*

Weight

- 3"H slat weight = 2 lbs./sq. ft.
- 1"H slat weight = 1.25 lbs./sq. ft.

Clearance/Tolerance

When installed, SoftenUp tiles have a consistent 1/8" reveal to account for any on-site tolerance concerns. Panels have a method for tile alignment integrated into the design.

** A continuous slat design is available. Contact us for details.*

MEP/FP

The panels can be trimmed on-site, using a sharp utility knife, to accommodate any MEP/FP fixtures. These include, but are not limited to, drop-in lighting and diffusers, recessed lighting, linear diffusers, concealed and exposed fire sprinklers, and A/V equipment. Please consult all local and municipal codes, as well as a licensed engineer, for full compliance requirements. Cut-outs must occur in 2" gap between slats. All fixtures must be supported independent of tiles.

**Panels cut on-site may require additional support.*

Ceiling Access

Panels with an integrated folding access tab are available upon request. These folding tabs allow for the removal of individual tiles to access ceiling systems.

Seismic

SoftenUp ceiling tiles can provide seismic compliance through a mechanical direct screw attachment through the panel to the grid system, or an individual tile off to building structure. Please consult all local and municipal codes, as well as a licensed engineer, for full compliance requirements.

